

# baby jogger®

## city mini® GT2

Stroller

CITY  
MINI® GT2



©2019 baby jogger NWL0000900480B 2/19

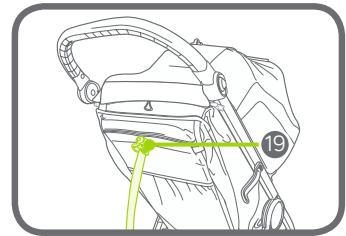
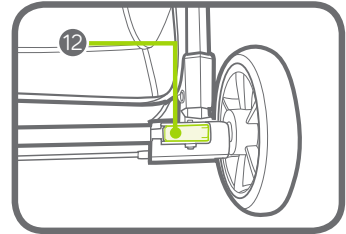
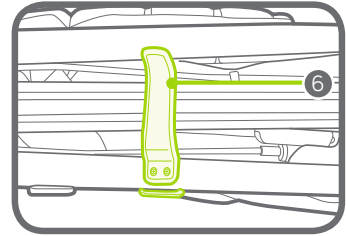
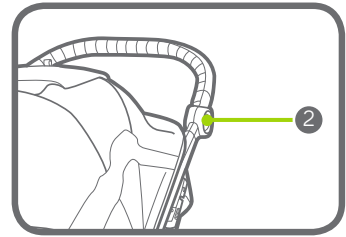
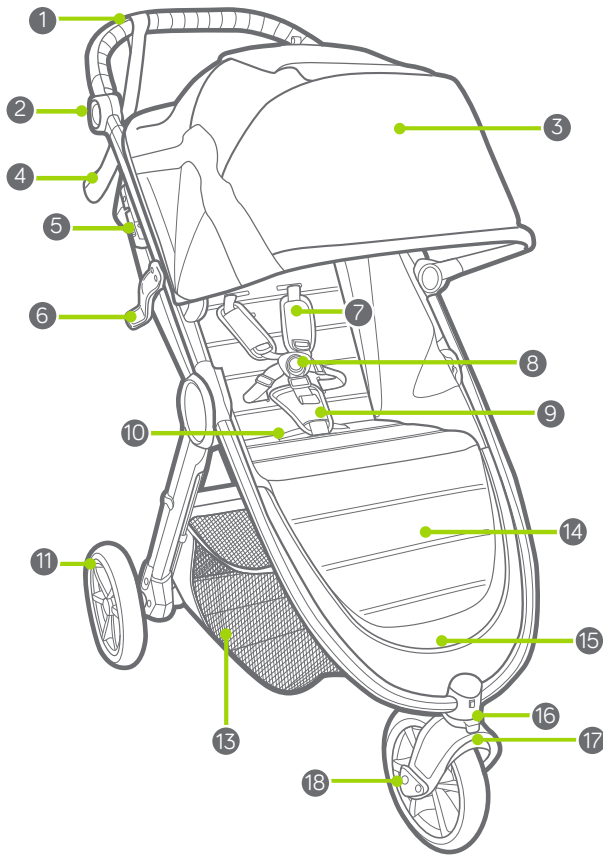

- |    |                       |    |                            |
|----|-----------------------|----|----------------------------|
| 1  | Handlebar             | 11 | Rear Wheel                 |
| 2  | Handlebar Fold Button | 12 | Rear Wheel Release Button  |
| 3  | Canopy                | 13 | Storage Basket             |
| 4  | Wrist Tether          | 14 | Leg Support                |
| 5  | Parking Brake         | 15 | Footwell                   |
| 6  | Auto-lock             | 16 | Front Wheel Release Button |
| 7  | Harness Pads          | 17 | Swivel/Lock                |
| 8  | Harness Buckle        | 18 | Front Wheel                |
| 9  | Crotch Strap Pad      | 19 | Seat Recline Strap         |
| 10 | Fold Strap            |    |                            |

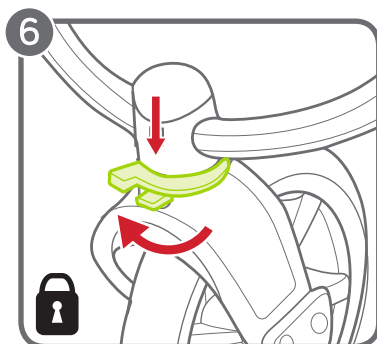
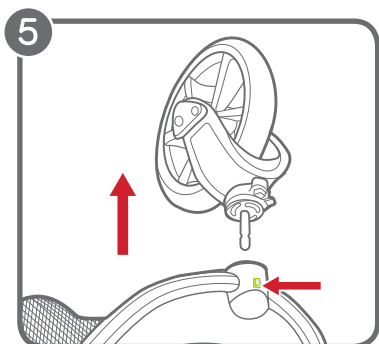
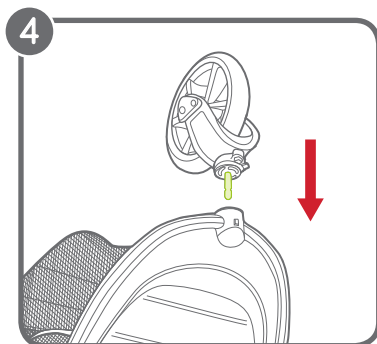
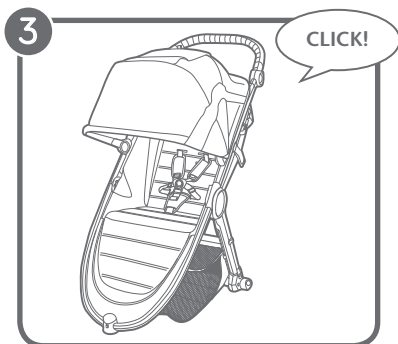
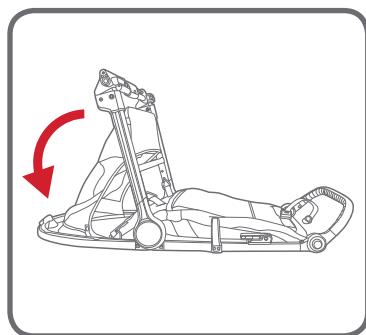
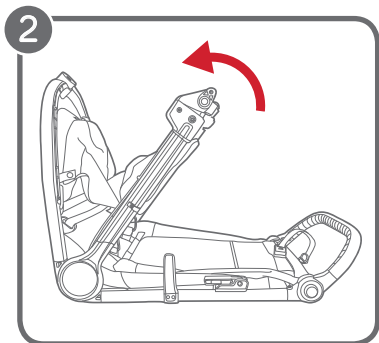
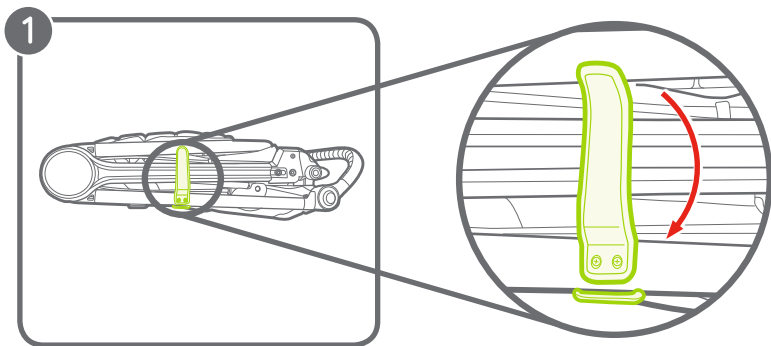

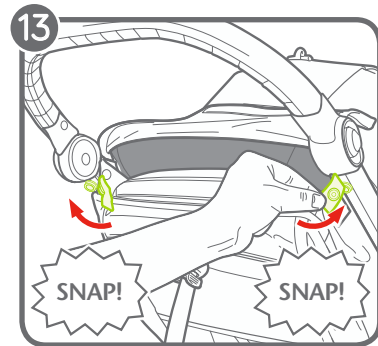
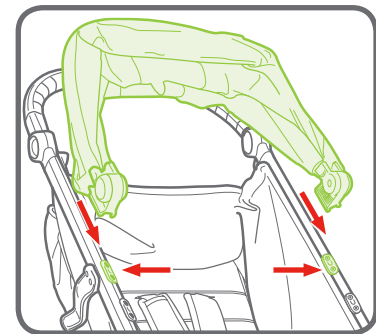
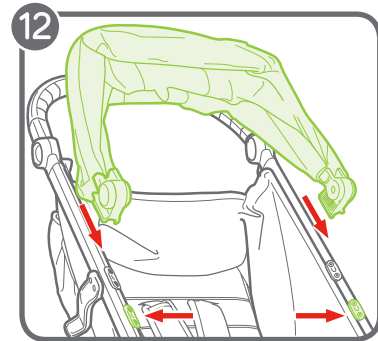
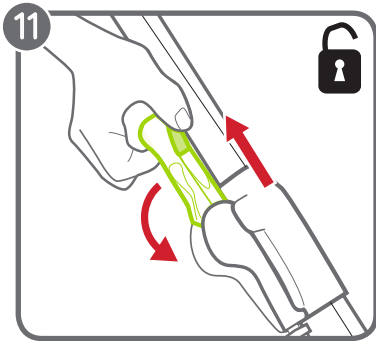
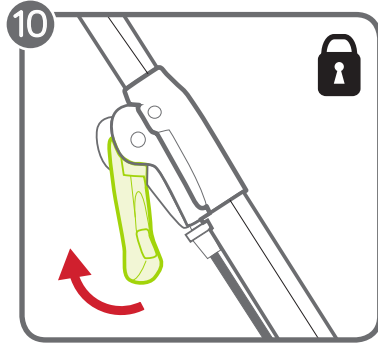
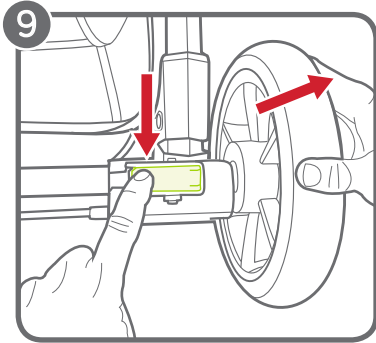
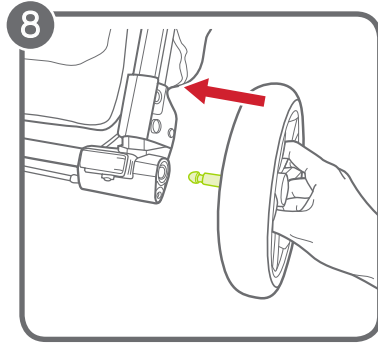
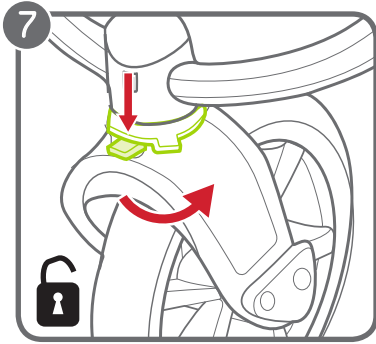

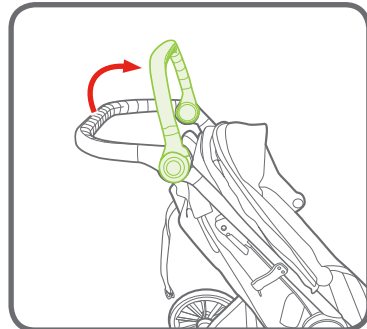
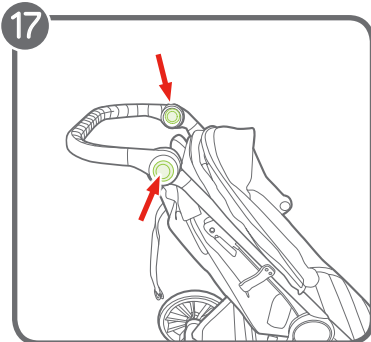
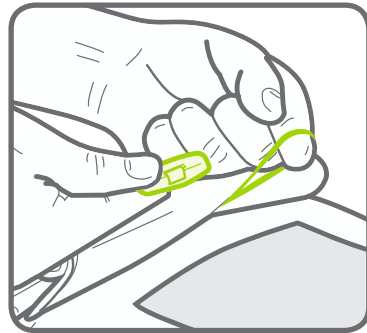
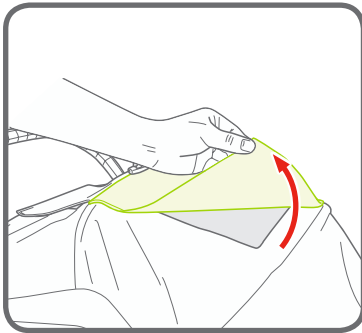
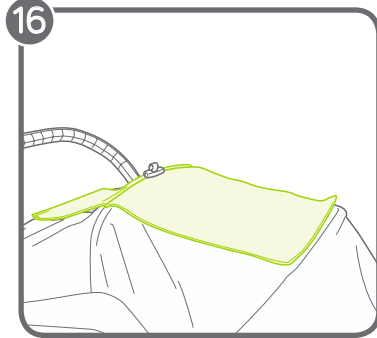
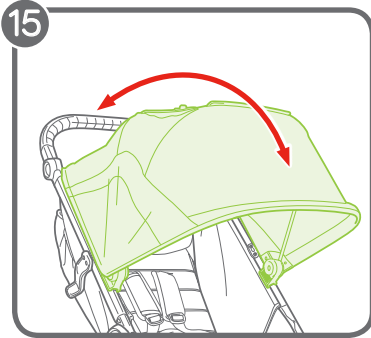
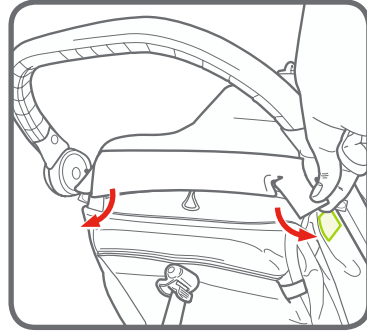
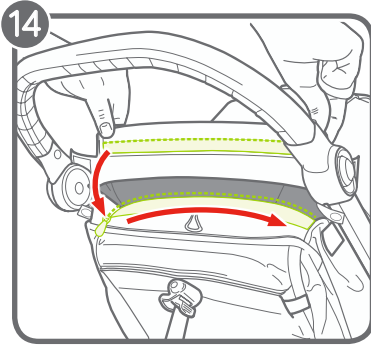

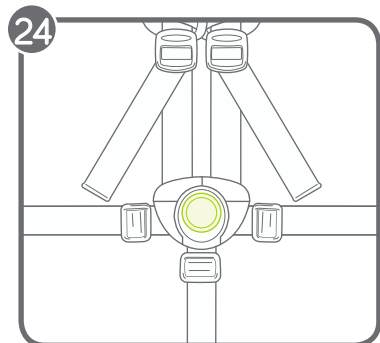
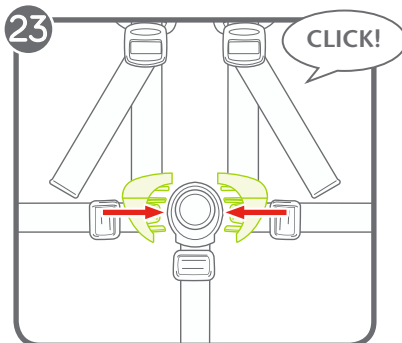
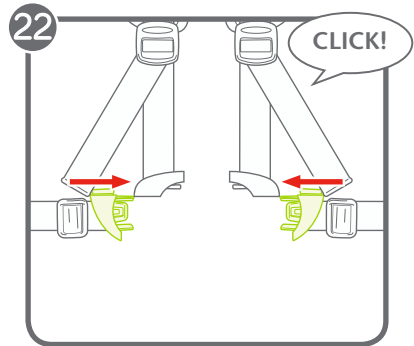
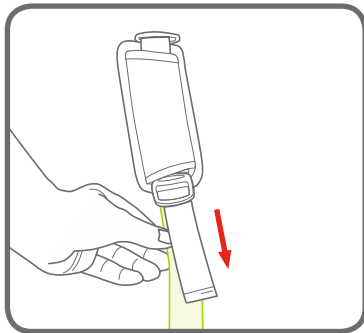
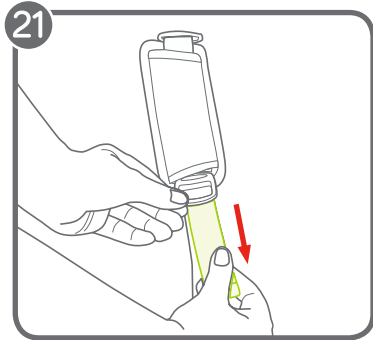
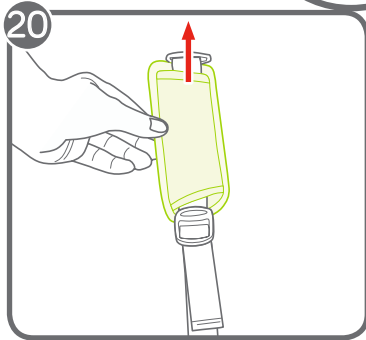
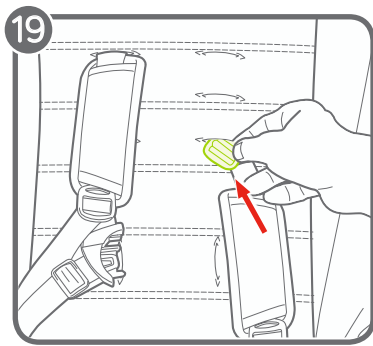
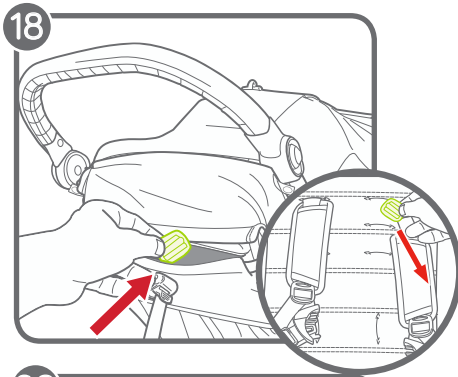

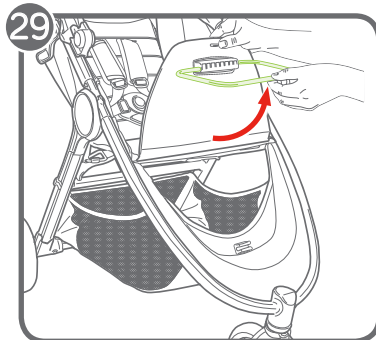
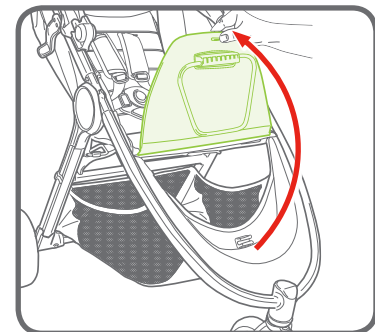
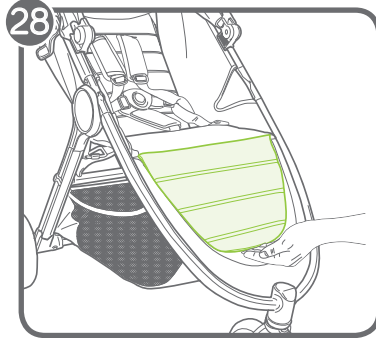
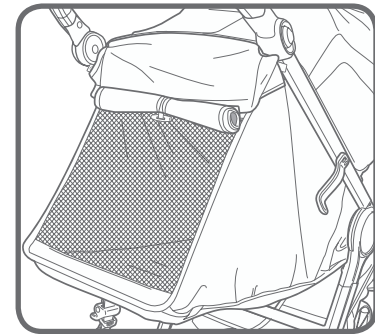
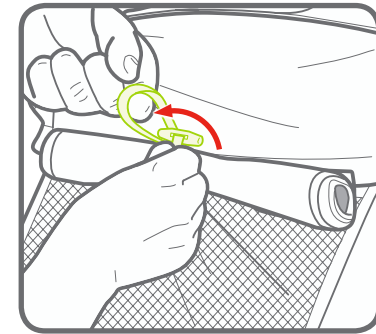
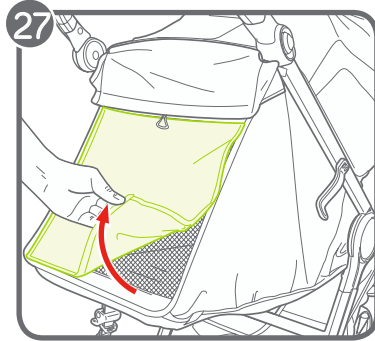
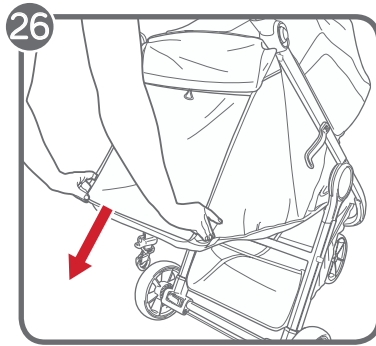
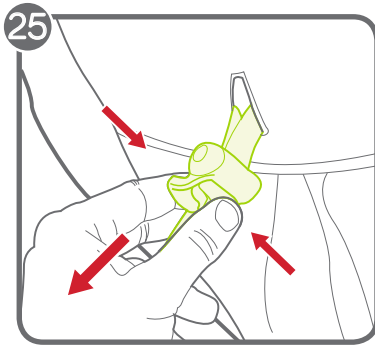

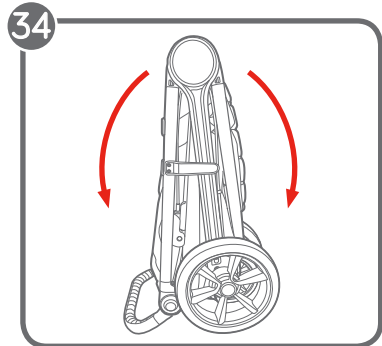
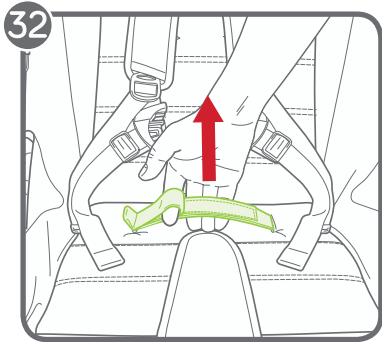
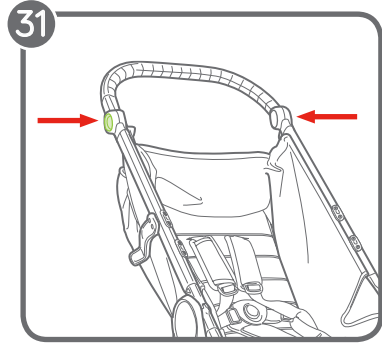
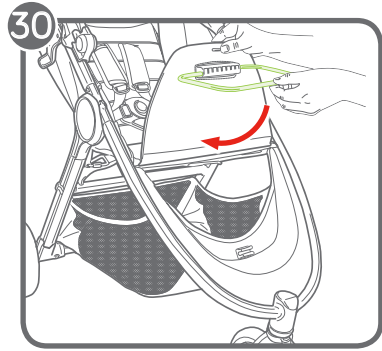
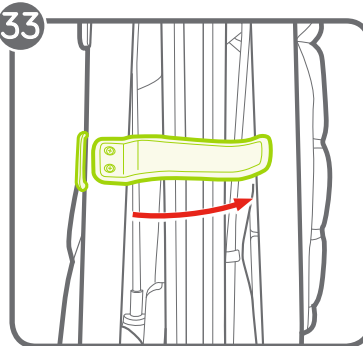
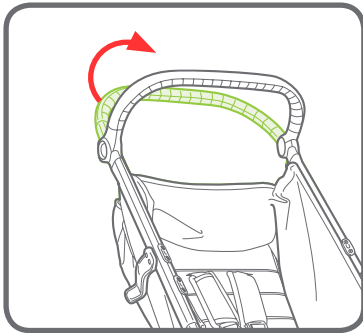
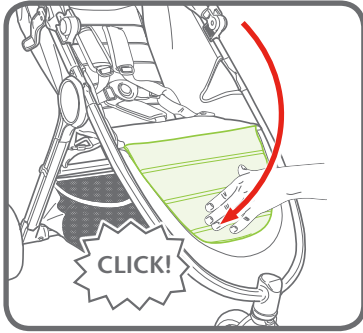
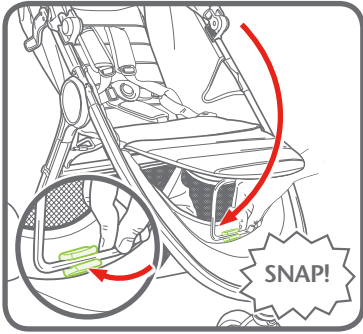



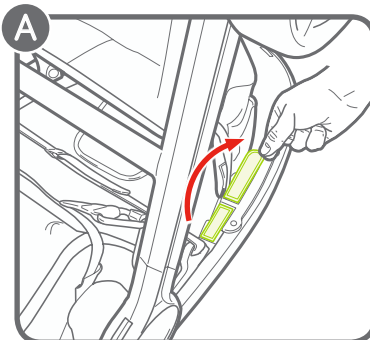
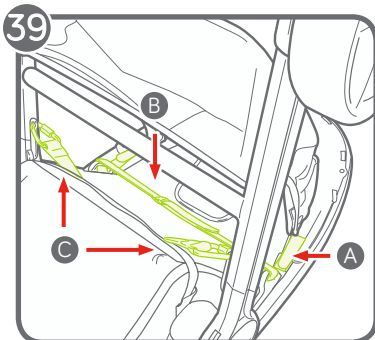
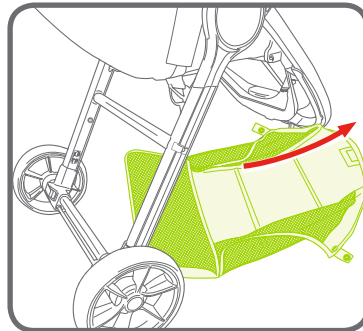
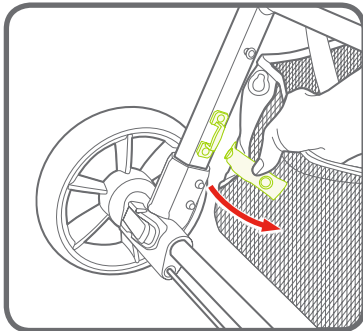
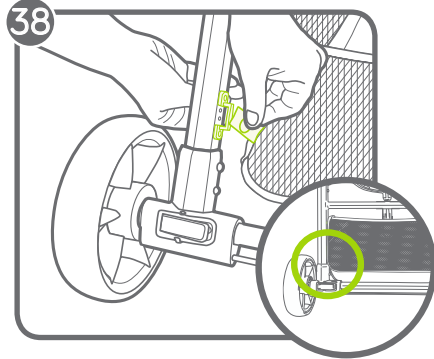
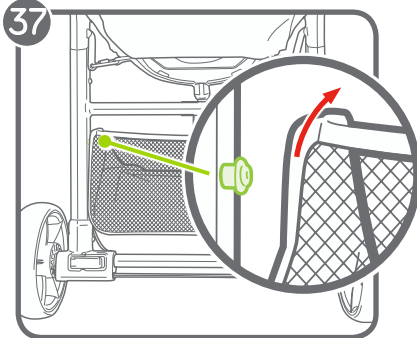
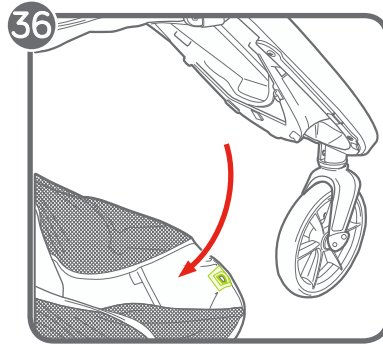
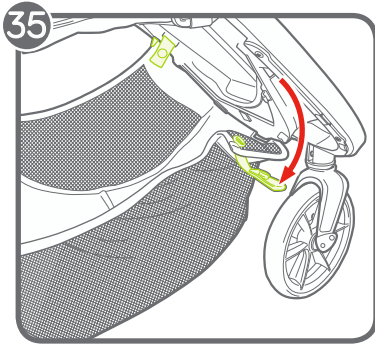

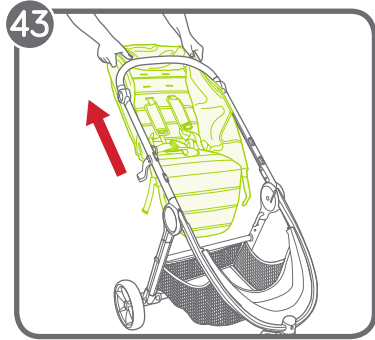
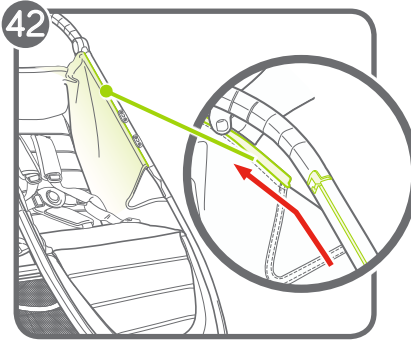
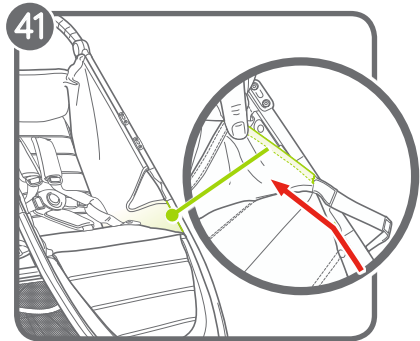
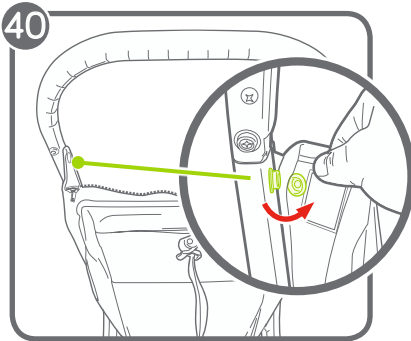
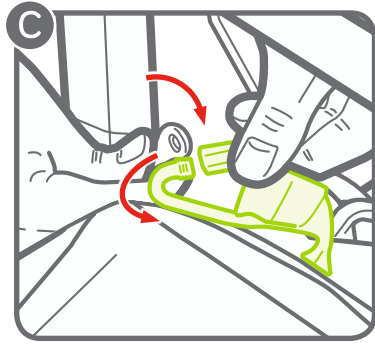
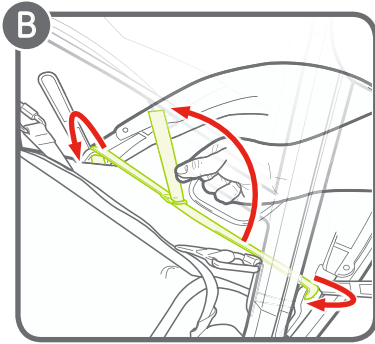

# WARNING

**IMPORTANT** - Keep these instructions for future reference.

Read these instructions carefully before use. Your child's safety may be affected if you do not follow these instructions.

## **SINGLE STROLLER**

- This stroller seats one passenger. NEVER allow more than one child at a time on this stroller.
- This seat is suitable for children from birth to 29.5 kg; maximum height is 112 cm.
- Total weight load recommended for this stroller is 35 kg, 29.5 kg in the seat, 1 kg in the seat back pocket, and 4.5 kg in the basket. Excessive weight may cause a hazardous unstable condition to exist.

### **WARNING: TO AVOID INJURY OR DEATH:**

- ALWAYS APPLY THE BRAKES WHENEVER THE STROLLER IS STATIONARY.
- DO NOT LEAVE CHILDREN UNATTENDED.
- SECURE THE CHILD IN THE HARNESS AT ALL TIMES.
- DO NOT CARRY EXTRA CHILDREN OR BAGS ON THIS STROLLER.
- MAKE SURE CHILDREN ARE CLEAR OF ANY MOVING PARTS IF YOU ADJUST THE STROLLER.
- **WARNING: USE THE STRAP TO STOP THE STROLLER ROLLING AWAY.**

### **WARNING: USE THE HARNESS AT ALL TIMES.**

- This stroller is not suitable for running, jogging, skating or rollerblading.
- Always use the restraint system.
- Check that the pram body or seat unit attachment or car seat attachment devices are correctly engaged before use.
- **WARNING: NEVER LEAVE THE HARNESS BUCKLED WHEN NOT FITTED TO A CHILD. THE HARNESS CAN FORM LOOPS THAT POSE A STRANGULATION HAZARD TO THE CHILD.**
- Accessories which are not approved by the manufacturer or distributor shall not be used.

- Do not let your child play with this product.
- Parcels or accessory items, or both, placed on the unit may cause the unit to become unstable.
- Any load attached to the handle and/or on the sides of the stroller affects the stability of the stroller.
- Ensure that all the locking devices are engaged before use.
- Lock the brakes before loading and unloading your child and whenever the stroller is not moving.
- Stroller is not meant to be used for transporting children up or down stairs or escalators. Damage resulting to stroller will not be covered under warranty.
- Be aware of the risk of open fire and other sources of strong heat, such as electric bar fires, gas fires, heaters, etc , in the near vicinity of the stroller.
- This stroller is designed for use on flat or gently sloping surfaces. Be aware that the possibility for tipping occurs if this product is used on higher sloping and uneven surfaces.
- Always keep fingers away from moving parts when folding, unfolding, or adjusting the stroller to prevent finger/body part entrapment or pinching.
- Before lifting and carrying the stroller, make sure the storage lock is properly secured.
- This stroller does not replace a cot or a bed. Should your child need to sleep, then it should be placed in a suitable pram body, cot, or bed.
- Accessories which are not approved by Baby Jogger shall not be used.
- Watch out for cars - never assume that a driver can see you and your child.
- The passenger shall remain seated (no standing in the stroller).
- It may be unsafe to use replacement parts other than those supplied or approved by Baby Jogger.

## FRAME

- 1 Unpack the stroller frame from the box and set the wheels aside. Unlock the stroller by pulling the storage lock Lever.
- 2 Unfold the stroller by pulling the handlebar away from the frame. The stroller will lock into place and you will hear a click.
- 3 Place the stroller in the upright position.

**⚠ WARNING:** Ensure that all the locking devices are engaged before use.

## FRONT WHEEL

- 4 Installation
  - Lay stroller on its back so the handlebar is resting on the floor.
  - Attach the Front Wheel by sliding it into the front wheel mount until it clicks. Gently pull on the Front Wheel to make sure it is properly attached.
- 5 Removal
  - While pressing the front wheel release button, gently slide the Front Wheel out of the front wheel mount.

## SWIVEL FEATURE

- 6 Push the swivel button down and rotate to the left to lock the front wheel assembly in a fixed position for long distance strolling.
- 7 Push the swivel button down and rotate to the right to allow the front wheel assembly to swivel.

**⚠ WARNING:** When loading and unloading child, lock the front wheel in a fixed position. Although the front wheel of your stroller locks, it is not intended for jogging or exercise purposes.

## REAR WHEELS

- 8 Installation
  - Align the rear wheel axle with the wheel mount on the stroller frame and insert it into the wheel mount until it locks into place. You will hear a click.

- Gently pull on the rear wheel to make sure it is properly attached.
- 9 Removal
    - While pressing down on the wheel release button, gently slide the rear wheel out of the wheel mount.

## BRAKE

- 10 To Lock the Brakes: gently pull the Brake Lever into upright position until it clicks into place.
- 11 To Release the Brakes: Pinch the gray tabs and pull the lever towards you. Push the Brake Lever down until it is parallel with the frame.

**⚠ WARNING:** Lock the brakes before loading and unloading your child and whenever the stroller is not moving.

## CANOPY

- 12 Attach the canopy to the frame by sliding the canopy onto one of two mounting brackets. To remove, slide canopy off of mounts.

NOTE: When using a City Go car seat, the canopy must be in the top position. For all other carseats, canopy must be removed.

- 13 Snap the two snaps to the stroller frame.
- 14 Zip the back of the seat to the canopy top. Attach the 2 fastening strips on the side of the canopy.
- 15 Pull forward to open canopy and push backwards to close canopy.
- 16 There are two canopy windows, a top one and back one. To use them, roll the shade up towards the top and secure with the elastic and button.

## Handle

- 17 To change the handle to one of 6 use positions, press the handle release buttons on both sides and rotate up or down to the new position.

## ADJUSTING SAFETY HARNESS

- 18 From the back of the seat, unfasten and open the pocket to locate the plastic square stopper. Turn stopper and pass through the openings in the PE board and seat fabric.
- 19 Reinsert stopper at seat opening closest to child's shoulders. Pass back through seat fabric and PE board. Tug on strap to ensure stopper is locked. Repeat on both sides.

**⚠️ WARNING:** Avoid serious injury from falling or sliding out. Always properly adjust and fasten safety harness.

**⚠️ WARNING:** Always use the crotch strap in combination with the shoulder straps and waist belt.

- 20 Slide the harness pads up to access plastic guide on strap.
- 21 Hold the plastic guide and pull strap to tighten or loosen.

## USING SAFETY HARNESS

- 22 Insert side strap buckle into harness buckle on both sides.
- 23 Insert connected harness and side strap buckles into the sides of the crotch buckle.
- 24 Press button on crotch buckle to release.

## RECLINE THE SEAT

- 25 Pinch the clamp behind the seat, and slide it down to desired recline.
- 26 Pull seat down on both sides to match the clamp position. Reverse steps to return to the upright position.

**⚠️ WARNING:** When making adjustments to the stroller seat, make sure child's head, arms, and legs are clear of moving seat parts and stroller frame.

- 27 For extra ventilation, roll up the seat back flap and secure with elastic and button.

## LEG SUPPORT

- 28 To use the leg support, lift the front of the seat pad.
- 29 Rotate the support arm out and lower the seat pad. Lock the support arm.

30 To lower leg support, reverse the steps.

## FOLDING

- Remove your child from the seat.
  - Disengage front wheel swivel locks.
  - Remove all attachments and all items from basket.
- 31 Press buttons on both sides of frame. Rotate handle up.
  - 32 Insert index finger into small loop, pull up on the "Pull to Fold" folding handle, and let the frame collapse.
  - 33 Make sure the auto-lock lever clicks into place.
  - 34 Place stroller upright in standing position.

## BASKET REMOVAL

- 35 From the front of the stroller, unsnap the 2 snaps and pull the straps out of the foot well.
- 36 Lift basket off the hook.
- 37 From the back, lift the top of the basket off the tab on both sides of the frame.
- 38 Unsnap the strap from the D ring on both sides of the frame.

## REMOVING THE SEAT FABRIC

- 39 Flip the stroller over to expose the seat bottom.
  - A Unfasten the 2 fastening strips and pull them out of the stroller frame.
  - B Unfasten the fastening strip and pull them out of the sides of the stroller frame.
  - C Unscrew both carabiner hooks and remove them from the stroller frame.
- 40 Flip the seat back over on its wheels. Unsnap both upper snaps from the stroller frame.
- 41 Starting from the bottom, slide the seat pad out from the stroller frame on both sides.
- 42 From the top, slide the seat pad out of the frame on both sides.
- 43 Remove seat fabric. Reverse the steps to reattach the seat pad to the frame.

# CARE AND MAINTENANCE

To preserve the longevity of your stroller, it is important to perform simple, regular maintenance. From time to time, make sure that the joints and folding areas are still in good condition. If you hear any squeaking or feel tension, you can take your stroller to a local bike shop for added lubrication. All repairs should only be carried out by an authorized dealer.

## WASHING

### Seat Fabric

- You can hand wash the stroller's seat in cold water with a mild detergent.
- Be sure to remove the metal frame and PE boards from the seat before washing.
- Do not use solvents, caustic or abrasive cleaning materials.
- To minimize shrinkage, simply reattach the seat to the frame to dry.
- Do not press, iron, dry clean, tumble dry or wring the fabric.
- If the seat covers need to be replaced, only use parts from a Baby Jogger Authorized Dealer. They are the only ones that are guaranteed to have been safety tested and designed to fit this seat.

### Plastic/Metal Parts

- Wipe clean using a mild soap and warm water.
- You must not remove, dismantle or alter any part of the seat folding mechanism or brakes.

### Wheel Care

- The wheels can be cleaned using a damp cloth. They will need to be dried completely with a soft towel or cloth.

## STORING

- Sunshine can fade seat fabric and dry out tires, so storing your stroller indoors will prolong its good looks.
- DO NOT store outside.
- Ensure that the stroller is dry before storing for prolonged periods.
- Always store the stroller in a dry environment.
- Store the stroller in a safe place when not in use (i.e. where children cannot play with it).
- DO NOT place heavy objects on top of the stroller.
- DO NOT store the stroller near a direct heat source such as a radiator or fire.

# Baby Jogger's Limited Lifetime Warranty:

Baby Jogger warrants that the frame is free of manufacturer defects for the lifetime of the product. Manufacturer's defects include but are not limited to the breaking of welds and frame tube damage. Textile or soft side materials and all other components shall be warranted for one year from the date of purchase (except for tubes and tires). Proof of purchase is required to make a warranty claim and the warranty is only extended to the original purchaser.

## THIS WARRANTY DOES NOT COVER:

- Normal wear and tear
- Corrosion or rust
- Incorrect assembly, or the installation of third party parts or accessories not compatible with the original design
- Accidental or intentional damage, abuse or neglect, or use on stairs or escalators.
- Commercial use
- Improper storage/care of the unit

This warranty specifically excludes claims for indirect, incidental, or consequential damages. The implied warranties of merchantability and fitness for a particular purpose is according to the specific warranty period for this model unit at time of purchase. Some states do not allow the exclusion or limitation of incidental or consequential damages, so the above limitations or exclusions may not apply to you. This warranty gives you specific legal rights, and you may also have other rights which vary from state to state. To know what your legal rights are in your state, consult your local or state consumer affairs office or your State's Attorney General.

If your stroller was purchased outside of the United States, please contact the distributor in the country nearest you. Their contact information can be found on our website at <http://www.babyjogger.ca>. Claims for warranty outside of the country in which the product was purchased may incur shipping charges.

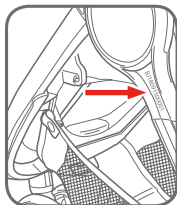

NOTE: When contacting Baby Jogger distributor regarding your stroller, please have your stroller's serial number ready. It can be located just below the hub on the outside of rear leg.

## IN AUSTRALIA CONTACT:

Call: 1300.661.885  
Fax: 03.9873.1433  
Mail: The Amazing Baby Company  
11 Maurice Court  
Nunawading, Victoria 3131  
Australia

## IN NEW ZEALAND CONTACT:

Call: (64) 03.338.7613  
Fax: (64) 03.338.7615  
Mail: Baby First Limited  
25 Nga Mahi Road  
Sockburn  
Christchurch, 8024  
New Zealand

Distributed in Australia By:  
The Amazing Baby Company  
11 Maurice Court • Nunawading VIC 3131 • Australia  
T: 1300.661.885 • F: 03.9873.1433  
[www.theamazingbabycompany.com.au](http://www.theamazingbabycompany.com.au)

Distributed in New Zealand By:  
Baby First Limited  
10 Moncur Place • Middleton Christchurch, 8024 • New Zealand  
T: (64) 03.338.7613 • F: (64) 03.338.7615  
[www.babyfirst.co.nz](http://www.babyfirst.co.nz)



Baby Jogger, LLC



6655 Peachtree Dunwoody Rd. NE • Atlanta, GA 30328  
1.800.241.1848 • [www.babyjogger.ca](http://www.babyjogger.ca)